

MG AFC 300 Alternator Field Controller

- Manual EN -

MG2000153 - MG AFC 300 Alternator Field Controller

MG Energy Systems B.V.





Copyrights © 2024 MG Energy Systems B.V.
All Rights Reserved

This publication or parts thereof, may not be reproduced in any form, by any method, for any purpose.

For conditions of use and permission to use this manual for publication in other than the English language, contact MG Energy Systems B.V..

MG ENERGY SYSTEMS B.V. MAKES NO WARRANTY, EITHER EXPRESSED OR IMPLIED, INCLUDING BUT NOT LIMITED TO ANY IMPLIED WARRANTIES OF MERCHANTABILITY OR FITNESS FOR A PARTICULAR PURPOSE, REGARDING THESE MG ENERGY SYSTEMS B.V. PRODUCTS AND MAKES SUCH MG ENERGY SYSTEMS B.V. PRODUCTS AVAILABLE SOLELY ON AN “AS IS” BASIS.

IN NO EVENT SHALL MG ENERGY SYSTEMS B.V. BE LIABLE TO ANYONE FOR SPECIAL, COLLATERAL, INCIDENTAL, OR CONSEQUENTIAL DAMAGES IN CONNECTION WITH OR ARISING OUT OF PURCHASE OR USE OF THESE MG ENERGY SYSTEMS B.V. PRODUCTS. THE SOLE AND EXCLUSIVE LIABILITY TO MG ENERGY SYSTEMS B.V., REGARDLESS OF THE FORM OF ACTION, SHALL NOT EXCEED THE PURCHASE PRICE OF THE MG ENERGY SYSTEMS B.V. PRODUCTS DESCRIBED HERE IN.

MG Energy Systems B.V. reserves the right to revise and improve its products as it sees fit. This publication describes the state of this product at the time of its publication and may not reflect the product at all times in the future.

TABLE OF CONTENTS

1	GENERAL	1
1.1	Document history	1
1.2	Terms, definitions, and abbreviations.....	1
1.3	This revision.....	2
1.4	Scope.....	2
1.4.1	Document structure	2
1.5	Related documents	2
2	SAFETY INSTRUCTIONS.....	3
2.1	Safety message level definition	3
2.2	User health and safety	3
2.2.1	General precautions	3
2.2.2	Qualifications and training.....	4
2.2.3	Non-compliance risks	4
2.2.4	Unacceptable modes of operation	4
3	TRANSPORT	5
3.1	Storage	5
3.2	Unpacking.....	5
3.2.1	Scope of delivery	5
4	GENERAL DESCRIPTION.....	6
5	INSTALLATION EXAMPLES	7
5.1	N/P-type field.....	7
5.2	P-type field with external PSU and with W/Tacho.....	7
6	MODELS.....	8
6.1	Identification label	9
7	OVERVIEW.....	10
7.1	General overview	10
7.2	General overview inside.....	11
7.3	Connection details	12
7.3.1	Power connections	12
7.3.2	Alternator connector	13
7.3.3	I/O connector	14
7.3.4	M12 CAN-Bus connector.....	15

7.4	Fuse	16
7.5	Status indication	16
8	INSTALLATION	17
8.1	Environment	17
8.2	Tooling.....	18
8.3	Installation procedure	18
8.4	Mounting.....	18
8.4.1	Mounting procedure	18
8.4.2	Connecting the power cables.....	20
8.4.3	Connecting the CAN-Bus cable to the Master	22
8.4.4	Connecting the alternator connector	23
8.4.5	Connecting IO connector (optional)	29
9	CONFIGURATION	31
9.1	Basic configuration and checks.....	31
9.2	MG Connect App (Bluetooth)	31
9.3	Updating firmware.....	33
9.3.1	Updating the firmware with the MG Connect App	33
9.3.2	Updating the firmware with the Victron VRM	33
9.4	Settings.....	34
9.4.1	Enable	34
9.4.2	Alternator current limit	34
9.4.3	Alternator temperature limit.....	34
9.4.4	Startup delay	35
9.4.5	Ignition/enable installed.....	35
9.4.6	W/Tacho installed	35
9.4.7	Alternator poles	35
9.4.8	Pulley ratio	36
9.4.9	BMS Monitor mode	36
9.4.10	Serial number BMS.....	36
9.4.11	Device instance BMS	36
9.4.12	External field power supply installed	37
9.4.13	Field voltage Limit	37
10	COMMISSIONING.....	38

11	OPERATION.....	39
11.1	States.....	39
11.1.1	Starting up.....	39
11.1.2	Charging not allowed.....	39
11.1.3	Field detection	39
11.1.4	Standby	40
11.1.5	Startup delay	40
11.1.6	Charging.....	40
11.1.7	Failsafe.....	40
12	DIAGNOSTICS AND TROUBLESHOOTING.....	41
12.1	Troubleshooting procedure	41
13	SERVICE	42
13.1	Maintenance.....	42
13.1.1	Connections	42
13.1.2	Cleaning	42
14	TECHNICAL SPECIFICATIONS.....	43
15	DIMENSIONS.....	43
16	CONTACT DETAILS.....	44
16.1	Sales	44
16.2	Technical support.....	44

1 GENERAL

Before continuing, read the instructions in this chapter carefully and be sure the instructions are fully understood. If there are questions after reading the instructions, please consult chapter 16.2 for technical support.

1.1 Document history

Revision	Date	Changes	Revision author
1.0	29-03-2024	Initial document	P. vd Schaar

Table 1 - Document history

1.2 Terms, definitions, and abbreviations

ATC	Allow-to-charge - A digital output used to control chargers.
Battery management controller	Controls, manages and protects one or multiple battery modules.
Battery pack	Consists of one or more battery modules in combination with a battery management controller (BMS).
Battery system	Consists of one or multiple battery packs connected to a common DC-bus.
(Master) BMS	Shorthand for a <i>battery management controller</i> in a MG energy systems battery system. Could be a Master LV or Master HV.
CAN-bus	<i>Controller Area Network bus</i> ; CAN-bus is a standard serial data bus that provides data communication between two or more devices.
DC-bus	Is the main DC-bus of the application where all user equipment is connected too, like generators, propulsion systems, other chargers and loads.
EMS	Energy management system
Failsafe	A condition of adequate level that causes an Alarm causing the battery pack to go into failsafe state.
NMEA 2000	<i>A plug-and-play communications standard used for connecting marine sensors and display units within ships and boats, standardised in the IEC 61162-1</i>
N-type field	One of the alternator field wires is internally connected to the positive terminal and the regulator needs to work reverenced to the negative terminal.
PMS	Power management system
PSU	Power supply unit
P-type field	One of the alternator field wires is internally connected to the negative terminal and the regulator needs to work reverenced to the positive terminal.

Table 2 - List of terms, definitions, and abbreviations

1.3 This revision

This revision replaces all previous revisions of this document. MG Energy Systems B.V. has made every effort to ensure that this document is complete and accurate at the time of writing. In accordance with our policy of continuous product improvement, all data in this document is subject to change or correction without prior notice.

1.4 Scope

This product manual contains technical description, installation, safety and commissioning instructions and other relevant information for the AFC 300.

1.4.1 Document structure

This document is structured into three categories:

- System design: Guidelines and general recommendations for system integrators and designers.
- Installation, commissioning and maintenance: Procedures and instructions for installers and maintenance personnel.
- Operation: Instructions and procedures for general users.

1.5 Related documents

More related documents for the AFC 300 can found on our [Download Centre](#).

2 SAFETY INSTRUCTIONS

This chapter describes the safety instructions applicable to this manual and product.

2.1 Safety message level definition



WARNING:

A hazardous situation which, if not avoided, could result in death or serious injury.



ELECTRICAL HAZARD:

The possibility of electrical risks if instructions are not followed in a proper manner.



NOTICE:

- A potential situation which, if not avoided, could result in an undesirable result or state.
- A practice not related to personal injury.

Table 3 - Safety message levels overview

2.2 User health and safety

2.2.1 General precautions

This product is designed and tested in accordance with international standards. The equipment should be used according to the intended use only.



ELECTRICAL HAZARD:

The product is used in combination with a permanent energy source (battery). Even if the equipment is switched off.

- Wear applicable personal protective equipment when working on a battery system.
- Use insulated tools during when working on a battery system.
- Make sure the local regulations for working on battery systems are followed.

2.2.2 Qualifications and training

The personnel responsible for the assembly, operation, inspection, and maintenance of the battery system must be appropriately qualified. The purchasing company is responsible for:

- Defining the responsibilities and competency of all personnel working with this product and all relevant systems.
- Providing instruction and training.
- Ensuring that the contents of the operating and safety instructions have been fully understood by the personnel.
- Ensuring that the system is installed in compliance to all local, federal codes or any other organism with jurisdiction over the system.

MG Energy system can, at the purchaser request provide all necessary training or instructions required for proper installation and usage of the system.

2.2.3 Non-compliance risks

Failure to comply with all safety precautions can result in the following conditions:

- Death or serious injury due to electrical, mechanical, and chemical influences.
- Environmental damage due to emission of hazardous substances.
- Product damage.
- Property damage.
- Loss of all claims for damages.

2.2.4 Unacceptable modes of operation

The operational reliability of this product is only guaranteed when it is used as intended. The operating limits on the identification tag and in the data sheet may not be exceeded under any circumstances. If the identification tag is missing or worn, contact MG Energy Systems B.V. for specific instructions.

3 TRANSPORT

The package and transport instructions provided by the manufacturer must be followed under all circumstances.

**NOTICE:**

No liability can be accepted for damage during transport if the equipment is not transported in its original packaging or if the original packaging is opened before the destination is reached.

3.1 Storage

The storage instructions provided by the manufacturer must be followed in all circumstances.

Notes on storage:

- Store in a dry and clean location.
- Store in the original packaging.

3.2 Unpacking

Follow these handling guidelines when handling the product to prevent damage during unpacking:

- Use care when handling the product.
- Leave protective caps and covers on the product until installation.

3.2.1 Scope of delivery

The scope of delivery is as following:

- MG AFC 300 – MGAFC480300
- IO connector – MG5001095
- Alternator connector – MG5001094
- Temperature sensor – MG3000438
- Quick installation guide – MG4000680
- Fuse FKS ATO 20A – MG5001100

**NOTICE:**

Not within the scope of delivery:

- Power cables and connectors.
 - Communication cables and connectors.
-

4 GENERAL DESCRIPTION

The MG AFC 300 is an alternator field regulator. It controls the alternator to charge an MG Lithium-Ion battery system. By controlling the field inside the alternator, the current from the alternator can be regulated. Together with a current and a temperature measurement on the alternator it can be protected from overheating. This also allows the AFC 300 to follow the setpoints from the connected BMS to charge the battery system under optimal conditions.

The AFC 300 has a build in load dump to protect the alternator, the AFC 300 itself and any connected peripheral equipment. If during the charging phase of the alternator the connected fuse breaks or the main safety contactor inside the BMS opens the AFC 300 will stop the charging of the alternator as quickly as possible and will clamp the voltage overshoot.

The AFC 300 supports a wide variety of alternators compatible with external field control. As long as one or both field wires come out of the alternator it can be connected to the AFC 300. The AFC 300 is capable to automatically sense what kind of field is connected. This way there are no different cable harnesses needed for different kinds of alternators. The AFC 300 supports 12 V, 24 V and 48 V battery systems.

Interfacing to the BMS is done through M12 CAN-Bus connector. And can be connected to a variety of different BMSs including the MG Master LV, MG SmartLink MX and MG SmartLink Connect. The standard CAN-bus protocol is based on NMEA2000. No additional EMS or PMS is needed, because direct control is possible.

To adjust any settings it is possible to directly connect to the AFC 300's build in Bluetooth module using the MG Connect App. The Bluetooth module can also turned off by a hardware switch if this is required.

Key features:

- Alternator protection.
- Temperature and current regulation.
- Automatic field polarity detection.
- Integrated load dump protection.
- Programmable digital input & output.
- Isolated M12 CAN-bus.
- NMEA2000 and DVCC compatible.
- Bluetooth for easy configuration.
- Fully encapsulated electronics for harsh environments.

5 INSTALLATION EXAMPLES

The AFC 300 is an alternator regulator and depending on the alternator, different connections can be made.

5.1 N/P-type field

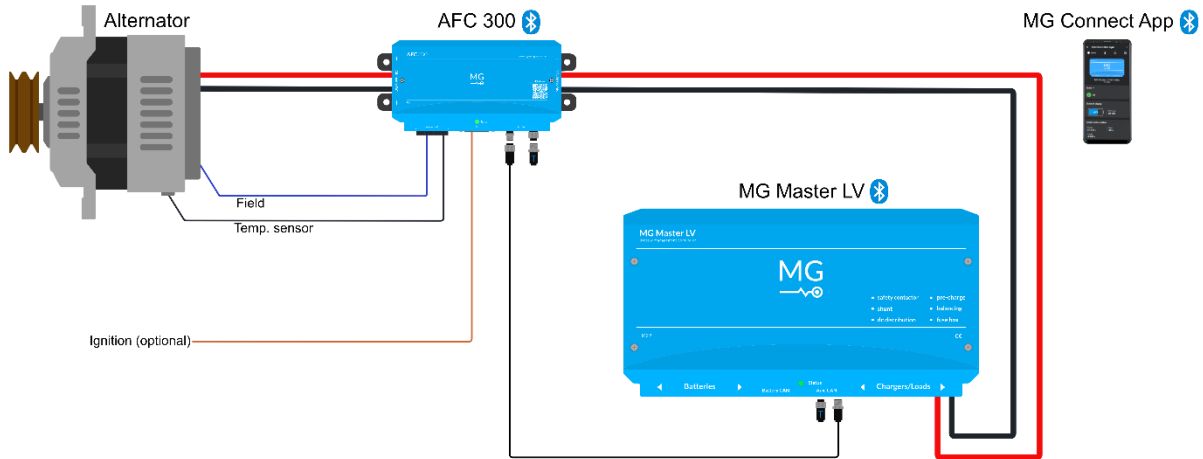

Figure 1 – Alternator with an N/P-type field

5.2 P-type field with external PSU and with W/Tacho

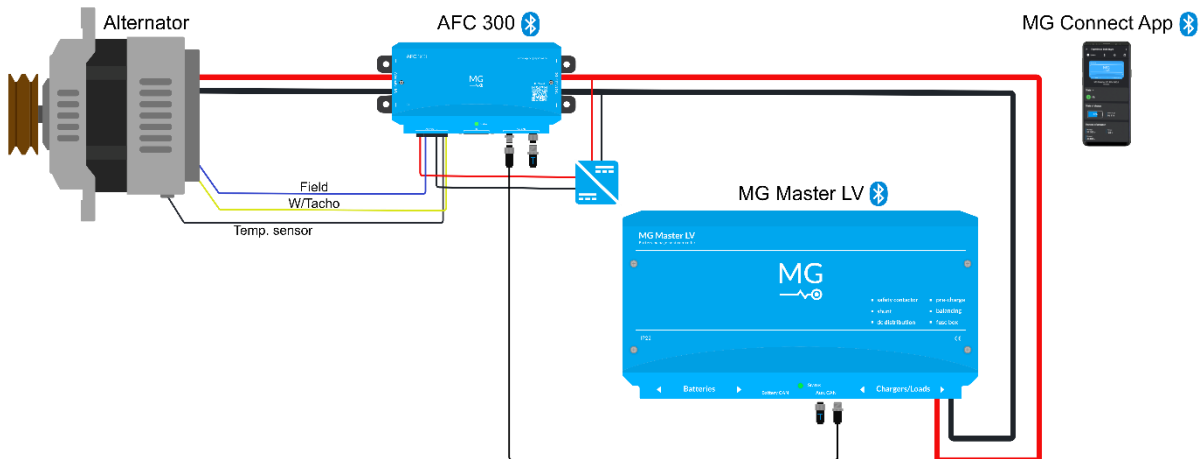

Figure 2 - Alternator with W/Tacho and field driven by external PSU

6 MODELS

This chapter shows the available models of the AFC 300.

Models and configurations

Product	Article number
MG AFC 300	MG AFC 480300

Table 4 - Model numbers

6.1 Identification label

There are two identification labels located on the AFC 300.

One of the Identification labels is located at the top side of the device.

Example identification label:

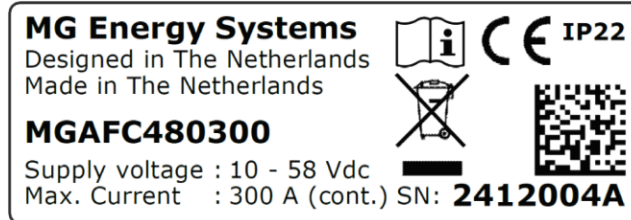

Figure 3 - Identification label example left side

The other identification label of the AFC 300 is located at the bottom side of the device.

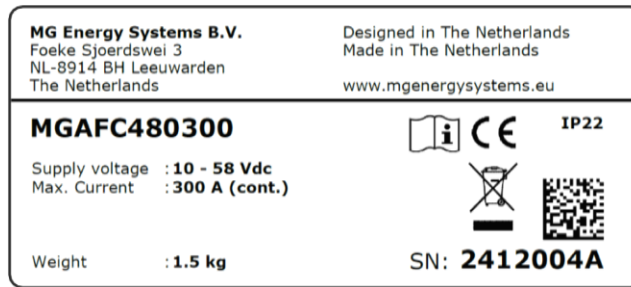

Figure 4 - Identification label example bottom side

The identifications label shown in Figure 3. Contains written information about the product. The explanation of the symbols used on the identification label is stated in Table 5.

	<p>Declaration of conformity with health, safety, and environmental protection standards for products sold within the European Economic Area as per directive 2014/35/EU.</p>
	<p>Symbol indication the manual must be read before installation and use of the device.</p>
	<p>Device is treated according the Waste Electrical and Electronic Equipment (WEEE) Directive 2012/19/EU.</p>
	<p>GS1 data matrix type barcode containing detailed product information.</p>

Table 5 - Identification table logo explanation

7 OVERVIEW

This chapter shows an overview of the AFC 300

7.1 General overview

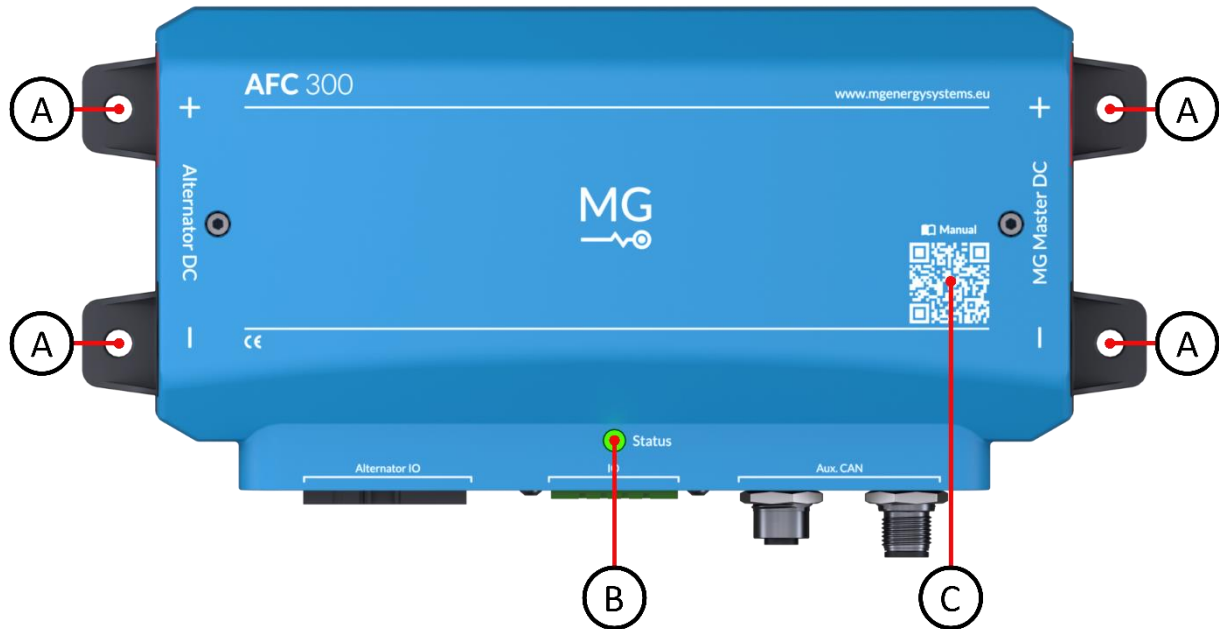

Figure 5 - AFC 300 overview front

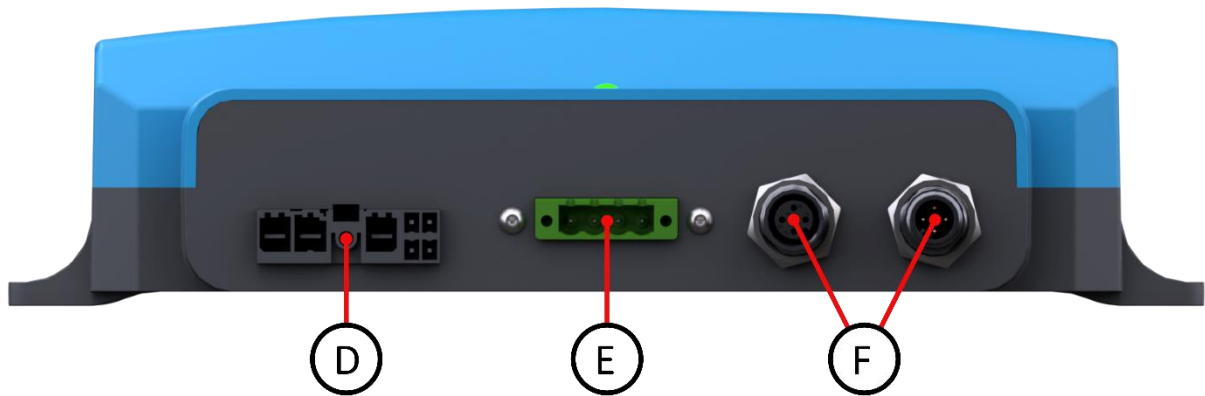

Figure 6 - AFC 300 connector overview

Part	Description
A	Mounting points
B	Status LED
C	QR-code for Manual
D	Alternator IO connector
E	IO connector
F	M12 Isolated CAN-Bus

Table 6 - Part descriptions

7.2 General overview inside

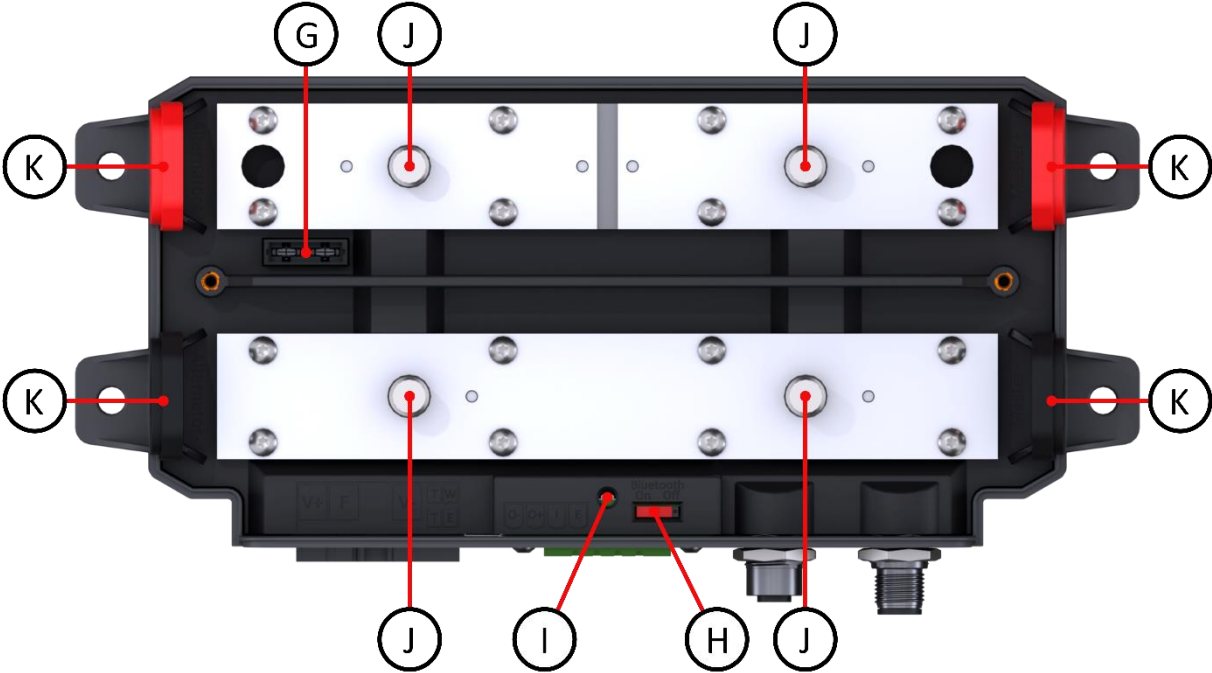

Figure 7 - AFC 300 internal overview

Part	Description
G	Fuse holder
H	Bluetooth switch
I	Status LED
J	Power connection bolts
K	Cable grommet

Table 7 - Part descriptions internals

7.3 Connection details

7.3.1 Power connections

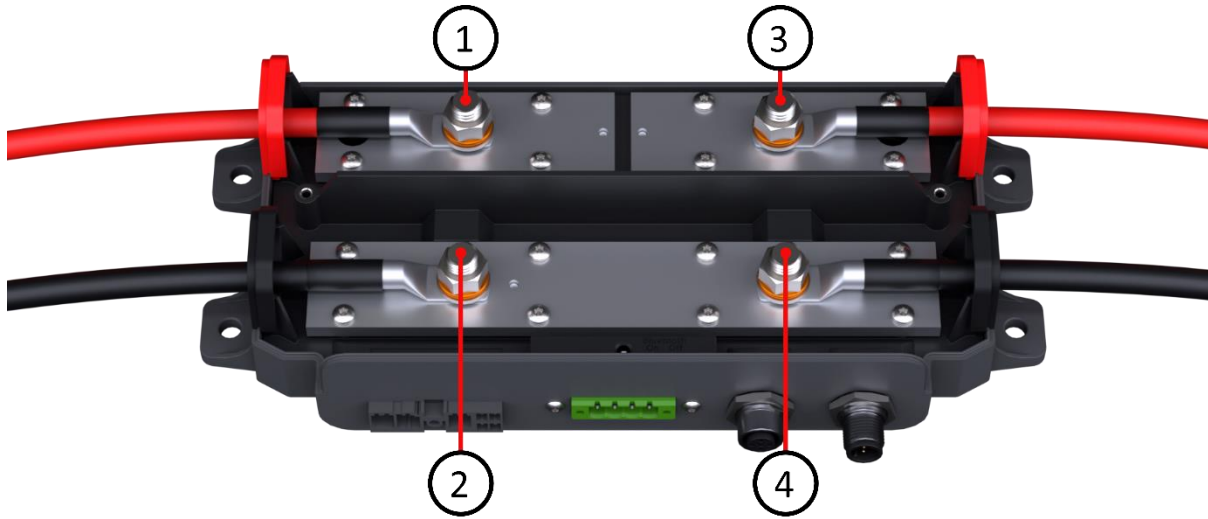

Figure 8 - Power connections

Connection specifications					
Name/Purpose	Bolt	Voltage	Current	Ø Cable	size
Alternator +	1	≤ 58 VDC	≤ 300 A	≤ 120 mm ² (250 MCM)	M10
Alternator -	2	GND			
Master +	3	≤ 58 VDC			
Master -	4	GND			

Table 8 - Power connections

7.3.2 Alternator connector

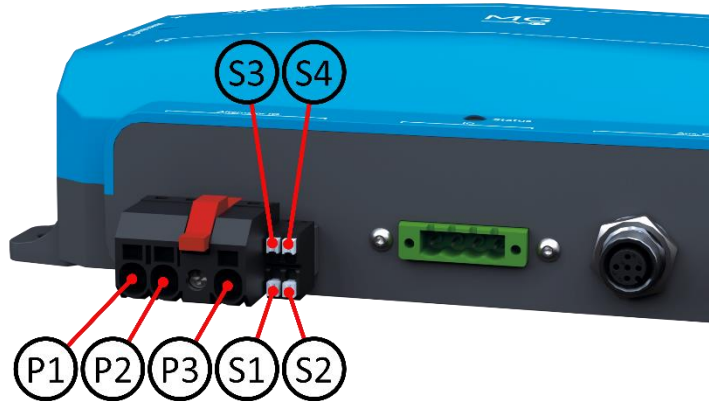

Figure 9 - Alternator connector pinout

Connector pins and specifications						
Name/Purpose	Pin	I/O	Voltage	Current	Ø Cable	Strip L
Field supply +	P1	In/Out	≤ 58 VDC	≤ 20 A	0.5-6 mm ² (20-10 AWG)	 14 mm (35/64")
Field	P2	Out	"Field supply +"			
Field supply -	P3	In/Out	GND			
Alternator Temperature -	S1	In	GND	< 1 mA	0.25-1.5 mm ² (24-16 AWG)	
Ignition/enable 7-58 VDC input for active detect	S2	In	≤ 58 VDC			
Alternator Temperature +	S3	In	≤ 3 VDC	< 1 mA		
W/Tacho	S4	In	≤ 58 VDC			

Table 9 - Alternator connector pinout



NOTICE:

The inputs and outputs of the connector are NOT isolated. Meaning the GND is connected to the internal GND busbar.

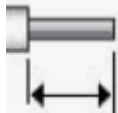
The Ignition/enable is electrically connected to pin '4' in the I/O connector.

7.3.3 I/O connector



Figure 10 - IO connector pinout

Connector pins and specifications						
Name/Purpose	Pin	I/O	Voltage	Current	Ø Cable	Strip L
Programmable output Return	1		GND	0.5 A	0.25-2.5 mm ² (24-14 AWG)	 10 mm (25/64")
Programmable output	2	Out	"Field supply +"	0.5 A		
Programmable input 7-58 VDC input for active detect	3	In	≤ 58 VDC	< 1 mA		
Ignition/enable 7-58 VDC input for active detect	4	In	≤ 58 VDC	< 1 mA		

Table 10 - IO connector pinout



NOTICE:

The inputs and outputs of the connector are NOT isolated. Meaning the GND is connected to the internal GND busbar.

The Ignition/enable is electrically connected to pin 'S2' in the alternator connector.

7.3.4 M12 CAN-Bus connector

The connectors used for connecting the CAN-bus are all of the same type, namely a circular M12 connector with 5 positions and A-coded keying.



NOTICE:

The AFC 300 has a **galvanically isolated CAN-bus**. This means it is not connected electrically to any other connections on the AFC 300.

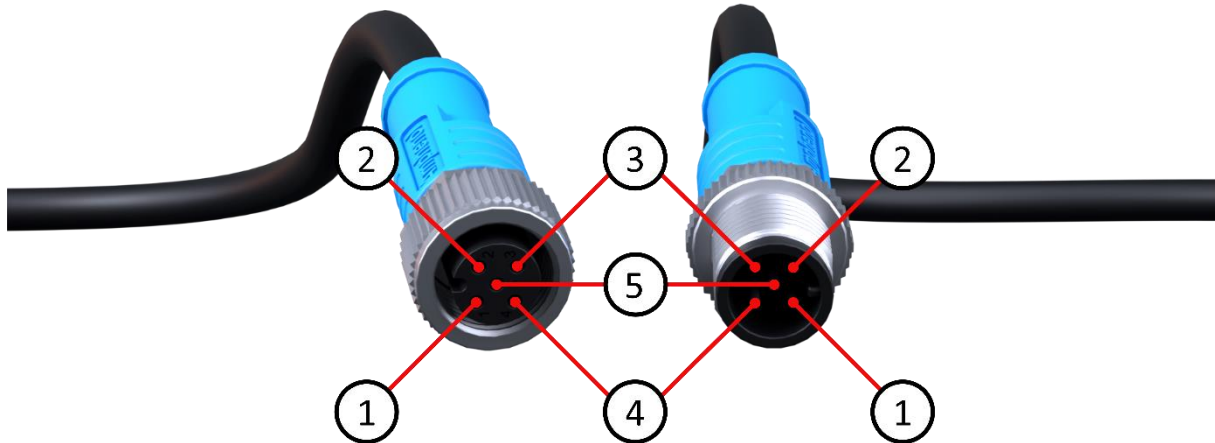

Figure 11 - M12 CAN-Bus connector pinout

Connector pins and specifications			
Name/Purpose	Pin	Voltage	Current
Shield	1		
CAN VCC	2	≤ 58 VDC	≤ 1 A
CAN GND	3		≤ 1 A
CAN-H	4		
CAN-L	5		

Table 11 - M12 CAN-Bus connector pinout

Cables to be used for the system are typically referred to as NMEA 2000 or DeviceNet compatible cables. The minimum requirements for cables are:

- Twisted pair connected to pins 4 and 5 for communication with a minimum wire cross sectional area of 0.2 mm² (24 AWG).
- Pair of conductors connected to pin 2 and 3 for power and HVIL with a minimum wire cross sectional area of 0.34 mm² (22 AWG).
- Cable with braided shielding connected to pin 1.



NOTICE:

Do not use sensor/actor cables. They often don't have any twisted pairs and are therefore not suitable for this application.

7.4 Fuse

When the field of the alternator needs to be driven with the same voltage as the busbars of the AFC 300 a fuse can be placed inside.

There are a limited number of fuses that fit. Table 12 shows a list of possible fuse types that fit inside the AFC 300.

Fuse type	Voltage	Current	Brand
ATC	≤ 32 VDC	≤ 20 Adc	Bussmann
ATO	≤ 32 VDC	≤ 20 Adc	Littelfuse
FKS ATO	≤ 80 VDC	≤ 20 Adc	Littelfuse

Table 12 - Fuse types suitable for the AFC 300

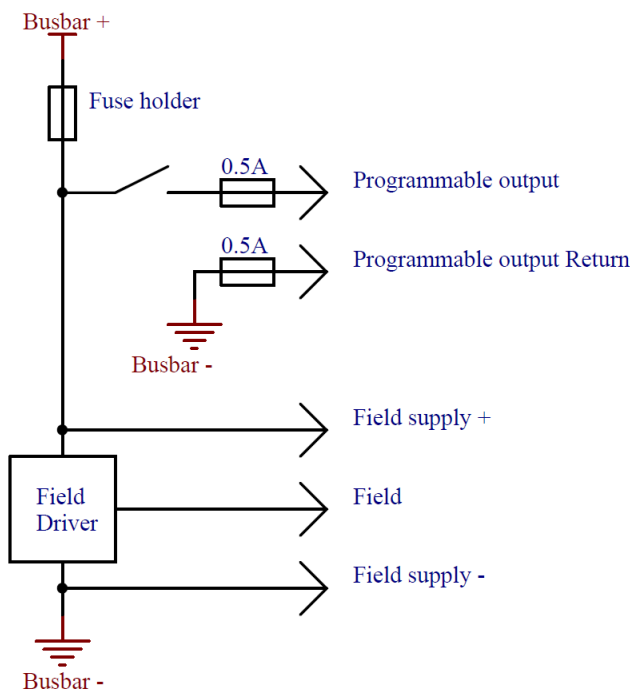

Figure 12 - Internal fuse connections

7.5 Status indication

The status indicator is a two-colour LED. This indicates the state of the AFC 300. Table 13 shows the status LED indication states and their meaning.

Status LED state	Description
Off	System off and is not powered
Blinking fast green	Charging not allowed
Short pulse green	Field detection
Long pulse green	Standby
On	Charging
5 Alternating green/red pulses	Error
Blinking red	In bootloader

Table 13 - Status indication

8 INSTALLATION

Read the installation instructions in this chapter before commencing installation activities.

WARNING:

Before continuing make sure the following instructions are met:



- Never replace a protective device by a component of a different type. Refer to the ordering information sections of this manual or contact manufacturer for a correct replacement.
- Before switching the device on, check whether the available DC bus voltage range conforms to the configuration of the product as described in the manual.
- Ensure that the equipment is used under the correct operating conditions. Never operate it in a wet or dusty environment.
- Ensure that there is always sufficient free space around the product.
- Install the product in an environment that can sustain some heat. Ensure therefore that there are no chemicals, plastic parts, curtains or other textiles, etc. in the immediate vicinity of the equipment.
- Do not install, modify or repair the AFC 300 while the system is in operation or energized as it may lead to damage of the Alternator, the Field regulator or both.

ELECTRICAL HAZARD:

- Wear applicable personal protective equipment when working on a battery system.
- Use insulated tools when working on a battery system.
- Make sure the locale health and safety regulations for working on battery systems are followed.

NOTICE:

During installation a check form needs to be used to log the installation procedure. This log will be checked during commissioning.

8.1 Environment

The AFC 300 has an IP rating of IP22 and must be placed in a space that is moisture and dust free, non-condensing and protected against fluid (water, oil etc.) ingress from top and bottom.



WARNING:

Moisture or water can damage the AFC 300 and its electronics. This might lead to dangerous situations.

8.2 Tooling

The required tools during installation are the following:

- Phillips screwdriver PH2 (insulated);
- Torque wrench M10 (17 mm) (insulated);

8.3 Installation procedure

Below the basic installation procedures:

1. Turn off battery system and ensure there is no voltage left on the system;
2. Mount the AFC 300;
3. Connecting the power cables to the alternator;
4. Connecting the field wire(s) to the alternator;
5. Connecting the power cables to the Master;
6. Connecting the CAN-Bus cables to the Master;
7. Connection IO cables (optional);

8.4 Mounting

8.4.1 Mounting procedure

The AFC 300 must be mounted vertically or horizontally against a flat surface.

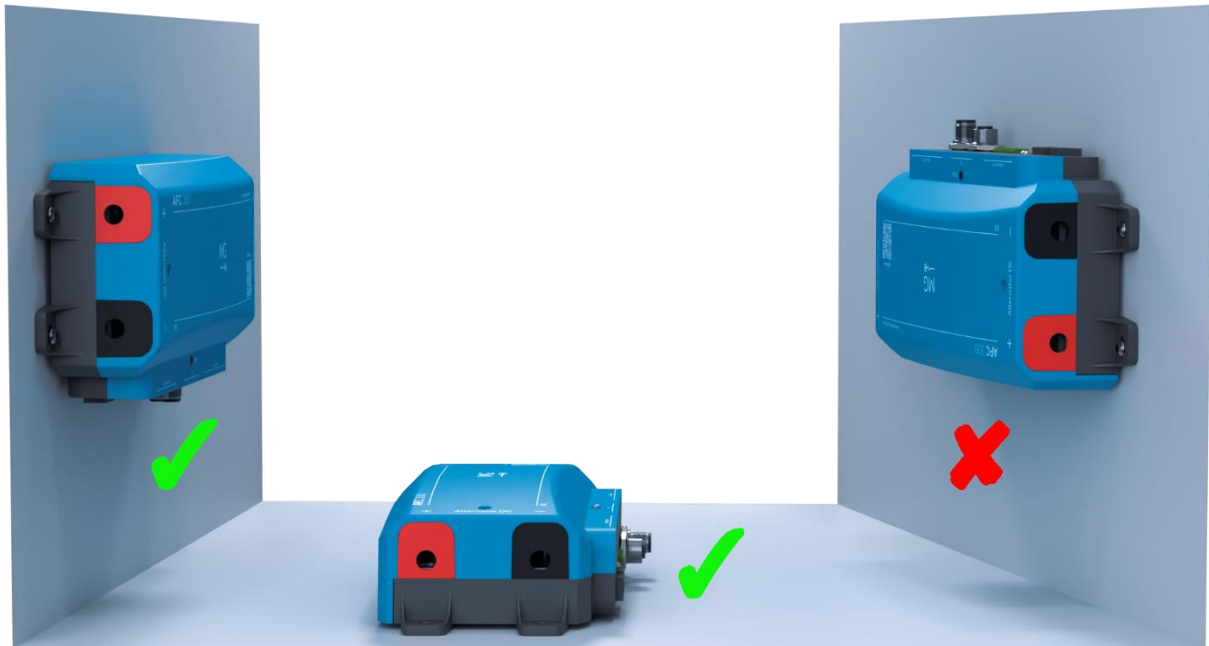

Figure 13 - Mounting direction

Mount the AFC 300 to a flat surface with the 4 mounting holes on the side of the device. Make sure there is enough space to connect all interfaces. The maximum fastener size that fits in the mounting holes is M6 (1/4”).



Figure 14 - Mounting the AFC 300



WARNING:
Countersunk screws should not be used. This can damage the mounting feet.

8.4.2 Connecting the power cables

1. Remove the top cover of the device.



Figure 15 - Remove top cover

2. Remove the cable grommets and cut them to size for the appropriate cable size.

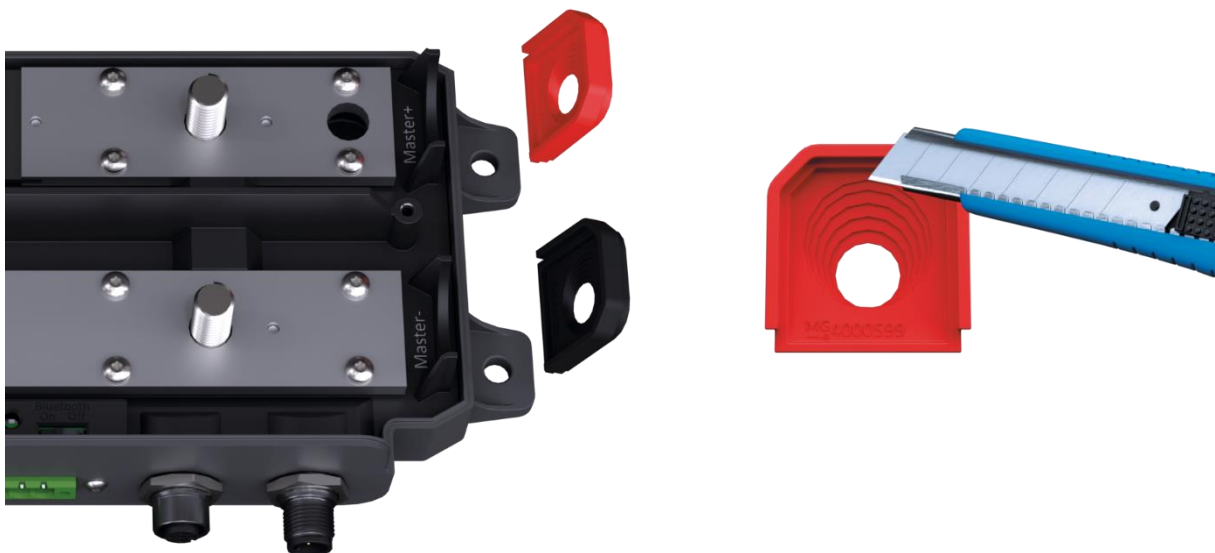

Figure 16 - Cut cable grommet to size

3. Remove the nut, spring washer and washers from the all the bolts connections.

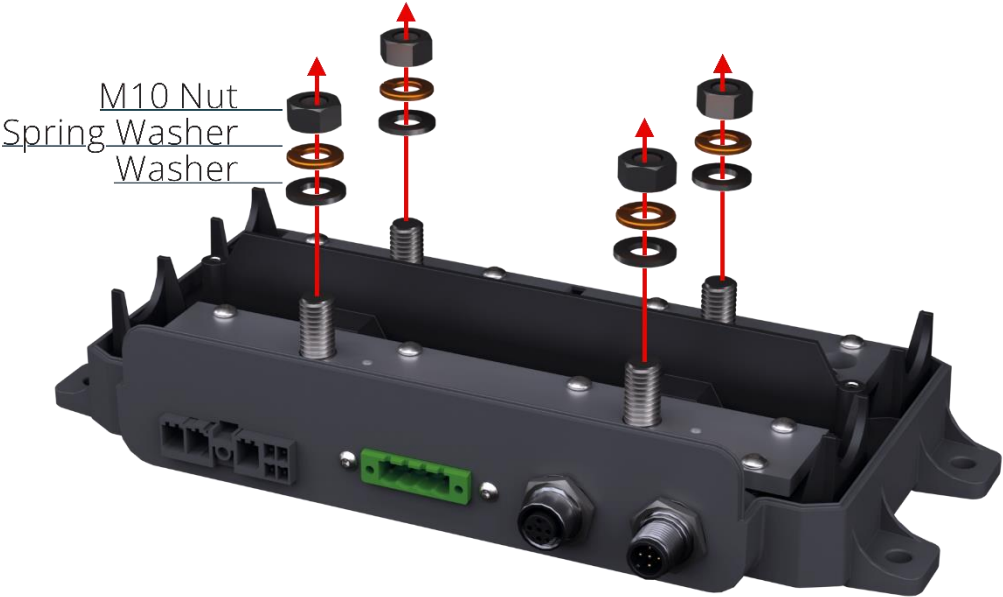

Figure 17 - Power connections

4. Place the alternator power cables on the bolts and place the washer, spring washer and nut back on the bolt. Tighten the nut with 30 Nm (22 lb-ft).



Figure 18 - Alternator power cables

- Place the power cables going to the Master on the bolts and place the washer, spring washer and nut back on the bolt. Tighten the nut with 30 Nm (22 lb-ft). It is recommended to fuse these cables appropriately.



Figure 19 - Master power cables

8.4.3 Connecting the CAN-Bus cable to the Master

The AFC 300 should be connected to the Aux. CAN-Bus that is connected to the Master. If it is the last device on the bus make sure to use a terminator to end the bus.



Figure 20 - CAN-Bus connection

8.4.4 Connecting the alternator connector

This connector is used to connect to the alternator. This includes driving the field of the alternator, measuring the speed and temperature of the alternator and finally also includes an additional possibility to connect to an external source for ignition/enable purposes.

This connector has a latch that must be pressed to disconnect the plug from the AFC 300. This latch can be found in Figure 21 ('Release') and must be pressed in the direction of the yellow arrow. The plug can also be fastened more secure by tightening the screw in the front of the connector.

This connector has two different cable connection methods, power connections and signal connections.

To install a wire in the power side of the connector;

1. Press white actuator until it locks.
2. Insert the cable.
3. Release the actuator.

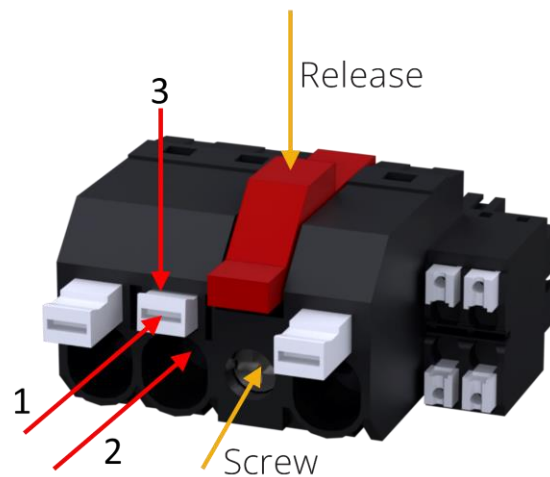

Figure 21 - Inserting wire into the alternator connector

Wires for the signal side of the connector can be inserted directly if they are either solid core or contain a wire end ferrule. For stranded wire without a wire end ferrule the actuator must be pressed during the wire insertion.

8.4.4.1 N or P type fields

The most common alternators that are capable of being driven by an external regulator are of the so-called N or P-type. Both of these alternators have one of the winding endings internally connected to the positive terminal or the negative terminal respectively. The other end of the winding is available on the outside of the alternator.

Both types can be connected in the same manner to the AFC 300. Connect the field wire to the ‘Field’ (P2) connection as is shown in Figure 22. The AFC 300 will detect automatically which type is connected and drive the field accordingly.

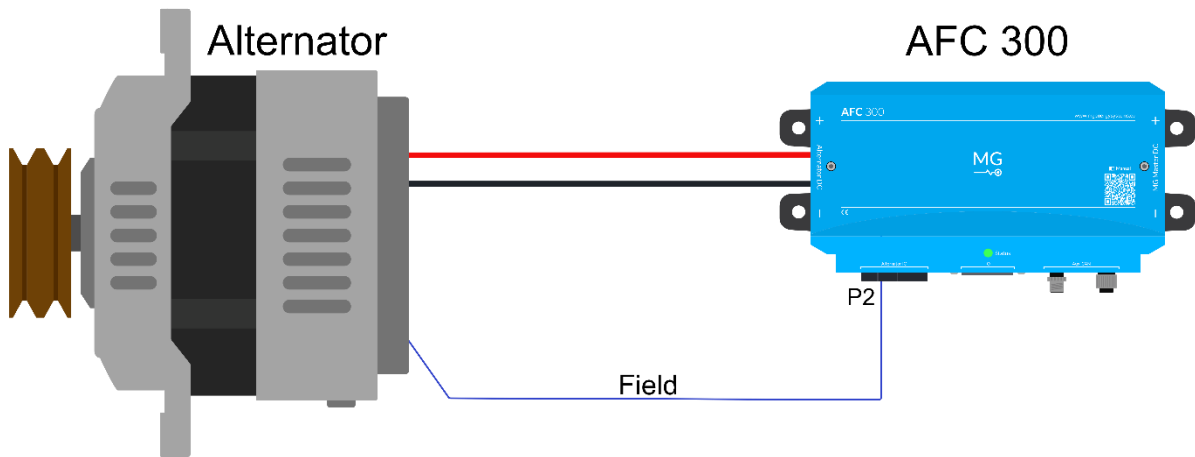

Figure 22 - N/P-Type field



NOTICE:

When the field of the alternator needs to be driven with the same voltage as is available on the internal busbars an appropriate fuse needs to be installed.

8.4.4.2 2 Wire fields

If both ends of the field windings are available on the outside of the alternator the user has the option to wire the field as either an N or P-type. Recommended is to wire the field as a P-type this can be done by connecting one of the field wires to “Field supply -“ (P3) on the Alternator connector or locally on the alternator by connecting one of the field wires to the negative terminal.

The other field wire can be connected to the ‘Field’ (P2) connection just as in the previous example.

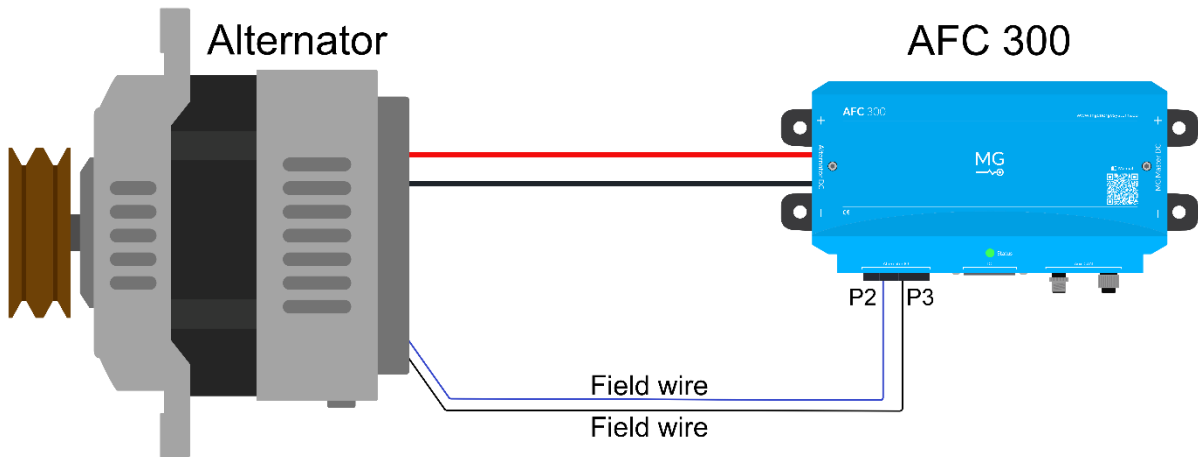

Figure 23 - 2 Wire field

8.4.4.3 Driving the field from an external PSU

In some cases, the field needs to be driven with a different voltage than the system voltage. In this case there are two options to drive the field.

Option 1;

The alternator is connected as normally but the field drive is limited in the settings. To do this please see section 9.4.13.

Option 2;

The internal field drive voltage can also be supplied from an external power supply. This feature cannot be used on an alternator with an N-type field (one wire (internally) connected to the Positive terminal). To drive the field from an external power supply, make sure there is no fuse installed in the AFC 300. Connect the external power supply negative wire to “Field supply -” (P3) and connect its positive wire to “Field supply +” (P1). The field wire of the alternator can be connected as normally to the ‘field’ (P2) connection. Finally, the setting should be configured accordingly so no broken fuse warning will be generated. This setting can be found in section 9.4.12. A diagram of how this fuse internally connected can be found in section 7.4 Figure 12.



WARNING:

- This feature cannot be used on an alternator with an N-type field
- The internal fuse should be omitted.

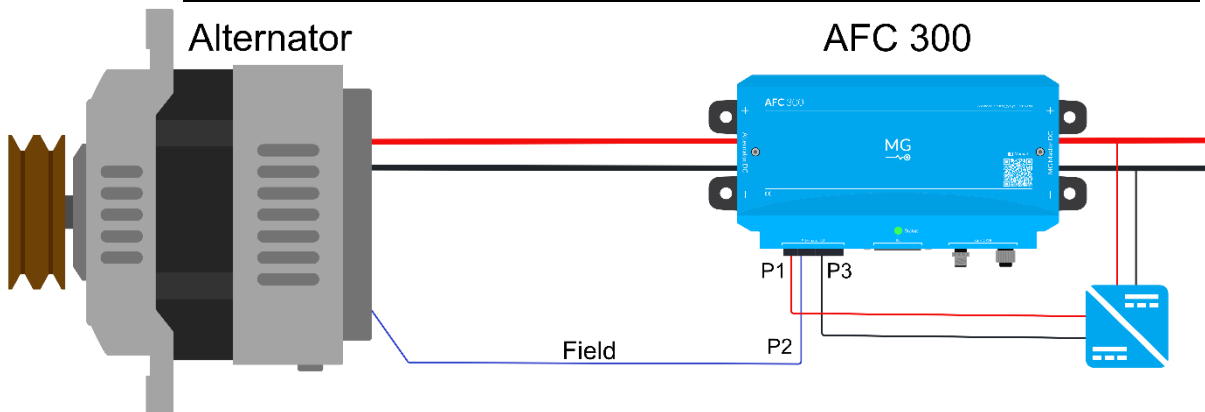

Figure 24 - Field with external power supply

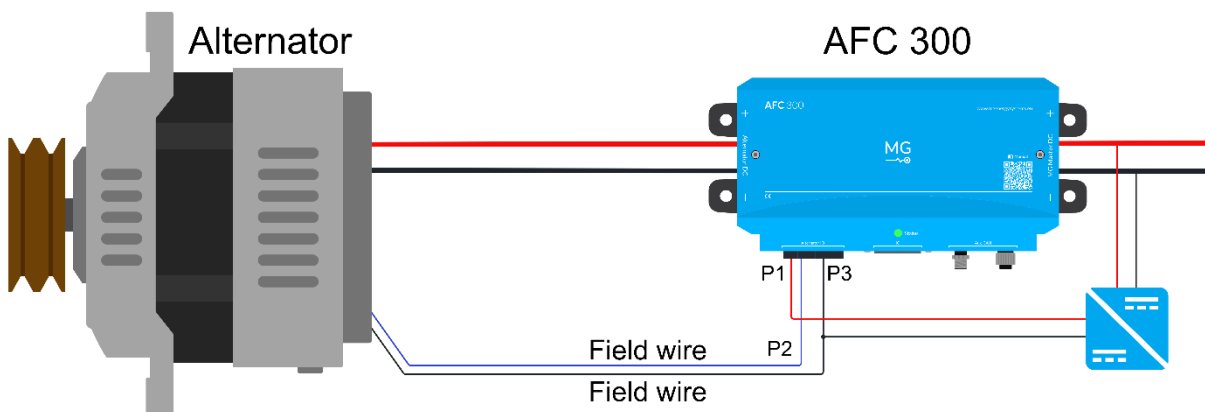

Figure 25 - 2 Wire field with external power supply

8.4.4.4 Connecting the temperature sensor: S1 & S3 (mandatory)

Ideally the temperature sensor should be mounted on the hottest part of the alternator. This isn't always possible and therefore it is recommended to mount the temperature sensor on top of the cable lug connected on the positive terminal of the alternator. See Figure 26.

Alternatively, the temperature sensor can be mounted on the frame of the alternator.

Refer to 7.3.2 for wiring connections.

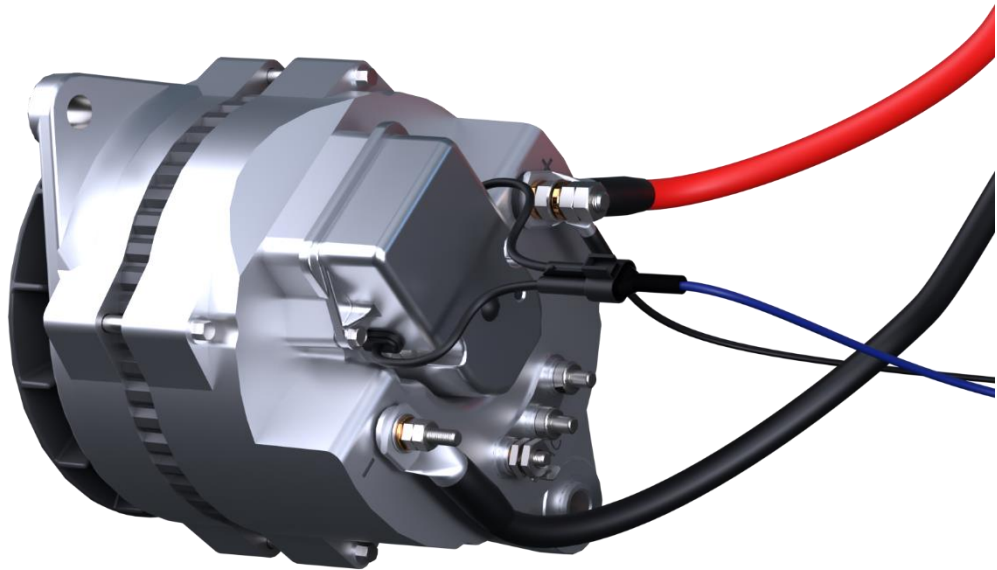

Figure 26 - Temperature sensor on top off the cable lug

8.4.4.5 Connecting the W/Tacho wire: S4 (optional)

This connection is used to measure and calculate the speed of the alternator and engine. This option is not available on all alternators but when available it is commonly designated as the 'W', 'Tacho' or 'AC' connection. This connection on the alternator can be directly connected to this input as long as it doesn't exceed the maximum ratings of the AFC 300. For reference see chapter 7.3.2. The settings that need to be set for this function can be found in sections 9.4.6, 9.4.7 & 9.4.8.



NOTICE:

For the AFC 300 to use this function and calculate the speed correctly the settings should be set accordingly.

8.4.4.6 Connecting the ignition/enable wire: S2 (optional)

When external control of the AFC 300 is needed to start or stop the charging process, this connection can be used. For example, it could be connected to an external oil pressure sensor or to a signal from the engine control unit to only allow charging when the engine is running.

If this option is used and the input is high the AFC 300 will start as normal. When the signal is low the AFC 300 will not enter standby and will not drive the field. This function is on by default.

If this option is not used the AFC 300 will still periodically drive the field in standby to check if this results in any current generated by the alternator. For full details see 11.1.4.

**WARNING:**

- This pin is internally/electrically connected to pin '4' in the I/O connector and it is not recommended to wire both at the same time.
-

**NOTICE:**

This connection is also available on the IO connector see 7.3.3.
For the AFC 300 to not use this function disable it in the settings see section 9.4.5.

8.4.5 Connecting IO connector (optional)

On this connector, the programmable inputs and outputs are available together with the ignition/enable input.

This connector can also be connected more securely to the AFC 300 by fastening the two screws on either side of the plug.

To insert a wire into this connector;

1. Raise the lever on top
2. Insert the wire
3. Lower the lever back down fully.

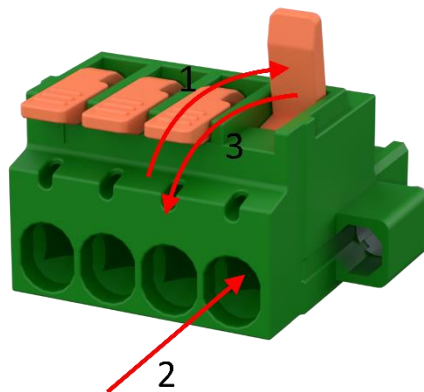

Figure 27 - Inserting wire into the IO connector

8.4.5.1 Connecting the programmable output: 1 & 2

These connections are protected by in internal self-resettable fuses. And is powered from “Field supply +”. A diagram of how this output internally connected can be found in section 7.4 Figure 12.



WARNING:

- Output voltage is not necessarily the same as system voltage.
- If the output is used for alarm purposes or failure indication, it may not work as expected when using the system voltage. The output will not become energized when the field fuse is blown. Installer must take this in consideration when designing, wiring this connection.

8.4.5.2 Connecting the programmable input: 3

8.4.5.3 Connecting the ignition/enable wire: 4

This connecting is also available on the alternator connector please refer to chapter 28 for information about this connection .



WARNING:

- This pin is internally/electrically connected to pin '4' in the I/O connector and it is not recommended to wire both at the same time.
-

9 CONFIGURATION

When the installation is completed and everything is connected the system can be powered and configured.

After powering the AFC 300 for the first time it is required to configure the settings in the device. Currently the device can only be fully configured with the MG connect app (Bluetooth).

9.1 Basic configuration and checks

To use the AFC 300 it is required to configure the device with the MG Connect App. This also makes it possible to save and restore configurations from and to a file.

Configure the settings to check and set:

- Maximum alternator current.
- Device to monitor and how by device instance or serial number.
- Check if an external ignition/enable setting is required.
- Check if the W/Tacho is settings are required.
- Check if there are settings required for potential limits on driving the field.



WARNING:

It is the responsibility of the installer/owner operator to properly set the parameters in the AFC 300 for the intended application. Failure to do so may lead to equipment failure, Fire or injury.

MG Energy Systems cannot be held liable for any direct or indirect consequences resulting from the improper settings and or modification of the parameters by the installer, owner or operator of the system.

In case of doubt contact MG Energy Systems dealer for reference.

9.2 MG Connect App (Bluetooth)

The internal Bluetooth module in the AFC 300 is enabled by default. The Bluetooth module can be turned on/off by using the internal red switch. Refer to section 7.2 for its location.

The next step is to install the MG Connect App ([Apple](#) or [Android](#)) on your phone or tablet and make a connection with the AFC 300. The default password is '000000'.

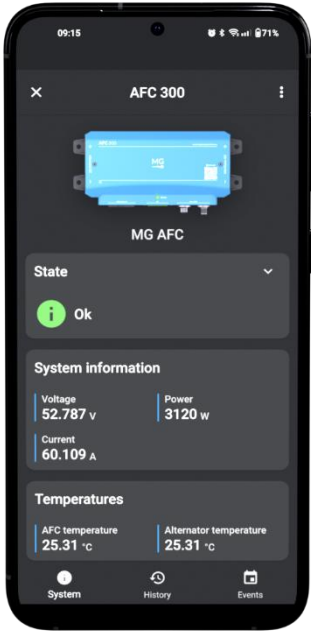

Figure 28 - Example MG Connect App on a phone

9.3 Updating firmware

The firmware of the AFC 300 can be updated using the MG Connect App or using the Victron VRM.

9.3.1 Updating the firmware with the MG Connect App

A complete guide for this process can be found on the following page.

<https://docs.mgenergysystems.eu/en/user-guides/mg-connect-app#update-device-firmware>

9.3.2 Updating the firmware with the Victron VRM

A complete guide for this process can be found on the following page.

<https://docs.mgenergysystems.eu/en/installation-guides/mg-victron-energy#remote-update-using-victron-vrm>

9.4 Settings

The following settings are available for the AFC 300. More information about specific settings or available options can be found in their specific chapter. Settings can be changed by using the MG Connect App on [Apple](#) or [Android](#).

9.4.1 Enable

The AFC 300 is only allowed to power the field when the enable setting is set to true. The field will never be powered when set to false.

Setting options	
True	Default
False	

Table 14 - Enable setting options

9.4.2 Alternator current limit

Maximum charge current the alternator can safely produce. Check the documentation for your alternator.

Setting options	
Min	0 A
Max	300 A
default	5 A

Table 15 – Alternator current limit setting options



NOTICE:

Most alternators cant continuously deliver their current rating. Recommended is to initially set this value to 50% of rated current. Test alternator performance under load and measure temperature with IR-camera. Increase value of this setting and test again.

9.4.3 Alternator temperature limit

Sets the maximum temperature the alternator can reach. When the alternator approaches this temperature, the field will be reduced. If this temperature is exceeded an error will be generated and the field will not be powered until the alternator cools down.

Setting options	
Min	50 °C
Max	90 °C
default	70 °C

Table 16 - Alternator temperature setting options



WARNING:

- The internal temperature of the alternator is in most cases significantly higher than the temperature measured on the outside.

9.4.4 Startup delay

Delay between the standby and charging state.

Setting options	
Min	0 s
Max	254 s
default	30 s

Table 17 - Startup delay setting options

9.4.5 Ignition/enable installed

This setting determines if an ignition/enable wire is installed. The ignition/enable wire is ignored when this setting is set to false. If set to true this input needs to be high before the AFC 300 will start charging.

Setting options	
True	Default
False	

Table 18 - Ignition/enable setting options



NOTICE:

It is recommended to use this option; Periodically testing the field for a running engine draws some current from the batteries which could be avoided by using this option.

9.4.6 W/Tacho installed

Determines if a W/Tacho is supposed to be connected. If no W/Tacho signal is detected while this setting is set to true the error “Tacho malfunction” will be generated.

Setting options	
True	
False	Default

Table 19 - W/Tacho setting options

9.4.7 Alternator poles

Number of poles the alternator contains. Used to determine the alternator speed. Only available when the W/Tacho installed setting is set to true.

The W/Tacho is an AC-signal proportional to the alternator speed. The number of poles is always an even number

Setting options	
Min	2
Max	254
default	2

Table 20 - Alternator poles setting options

9.4.8 Pulley ratio

Ratio between the drive pulley diameter and the alternator pulley diameter. Used to determine the engine speed. Calculated as: $\frac{\text{Drive pulley diameter}}{\text{Alternator pulley diameter}}$. Only available when the W/Tacho installed setting is set to true.

Setting options	
Min	0.50
Max	10.00
default	3.00

Table 21 - Pulley ratio setting options

9.4.9 BMS Monitor mode

Determines whether the AFC 300 is supposed to listen to a serial number or a device instance.

Setting options	
Device instance	Default
Serial number	

Table 22 - BMS monitor mode setting options

9.4.10 Serial number BMS

This is the serial number of the device that controls the AFC 300.

Setting options	
List with selectable serial numbers	

Table 23 - Serial number setting options

9.4.11 Device instance BMS

This is the device instance of the device that controls the AFC 300. Only a single MG device may have this device instance. This will not change the device instance of the AFC 300 itself.

Setting options	
Min	0
Max	250
default	0

Table 24 - Device instance setting options

9.4.12 External field power supply installed

This setting needs to be set to true when the field power is supplied by an external power supply. If the field is supplied by an external power supply while this setting is false a broken fuse error will be generated.

Setting options	
True	
False	Default

Table 25 - External field setting options



WARNING:

- The internal fuse should be omitted when set to true.

9.4.13 Field voltage Limit

Maximum allowed voltage for the field winding. For most alternators the field should be driven with the same voltage as the system voltage. For the alternators that have a field shat should be driven with a lower voltage this setting can be used to limit the effective voltage with which the field is driven.

Setting options	
System voltage	Default
12 V	
24 V	
48 V	

Table 26 - Field voltage setting options

10 COMMISSIONING

Table 27 shows a list of points that need to be checked after installation

	Description
<input type="checkbox"/>	Are the environment and placement requirements in chapter 8.1 and 8.4.1 met?
<input type="checkbox"/>	Is the AFC 300 installed in a location where there is no possibility fluids can enter? For example, installation under the seams of hatches.
<input type="checkbox"/>	Is the AFC 300 clean from any dust, metal pieces and loose wires?
<input type="checkbox"/>	Is the correct fuse placed in the Master?
<input type="checkbox"/>	Are all power connections tightened to 30 Nm (22 lb-ft)?
<input type="checkbox"/>	Are all CAN-Bus cables connected?
<input type="checkbox"/>	Are CAN-bus termination resistors installed in the correct way?
<input type="checkbox"/>	Is the ignition/enable input functioning properly? (When used)
<input type="checkbox"/>	Is the W/Tacho input functioning properly? (When used)
<input type="checkbox"/>	Are all settings correctly set?
<input type="checkbox"/>	Perform a charge test run and measure the temperature of the power connection terminals during the test. Is there excessive heat generation in the system or system components?
<input type="checkbox"/>	Make pictures of the installation.
<input type="checkbox"/>	Send the pictures and this form together with the system commissioning form to support@menergyssystem.eu with the subject: <project name> - Commissioning.

Table 27 - Commissioning steps procedure

11 OPERATION

This chapter will describe how the AFC 300 operates. To function, the AFC 300 uses a state machine. The states in which it operates is explained in the following section.

Once the AFC 300 is in the “Charging” state it will try to regulate the alternator output to its setpoint. The setpoint to which it is trying to regulate is limited by multiple inputs. The input to which it is currently limited can be viewed in the MG Connect App. The limiting factor can be any of the following sources;

- Charge current limit setting
- BMS (current/voltage)
- SmartLink MX
- Alternator temperature
- Field current

11.1 States

When the AFC 300 is powered, it first enters the “Starting up” state and moves to other states when certain conditions are met.

11.1.1 Starting up

In this state various services are initialized. The AFC 300 will enter the “Charging not allowed” state when all services are successfully initialized and all data is received.

11.1.2 Charging not allowed

The AFC 300 will enter the “Charging not allowed” state after starting up and whenever charging is not allowed. Reasons for charging to not be allowed:

- Device is disabled in settings.
- Ignition/enable is low and the “Ignition/enable installed” setting is set to true in Bluetooth Connect App settings.
- Maximum charge current is set to 0 A in Bluetooth Connect App settings.
- The alternator temperature exceeds maximum temperature set in Bluetooth Connect App settings.
- No active BMS matches settings set in Bluetooth Connect App settings.
- The active BMS does not allow charging.
- An error has occurred.

The AFC 300 will enter the “Field detection” state when none of the above is true. Receiving data from the master can take several seconds.

11.1.3 Field detection

While the AFC 300 is in this state it will continuously try to detect a field. When no field is detected, it will remain in this state. When a field is detected, the “Standby” state will be entered.

11.1.4 Standby

While the AFC 300 is in the “Standby” state it will ramp up the field its maximum output. If during the ramp-up the AFC 300 detect that the alternator starts charging it will immediately go to the “Startup delay” state. The field will be disabled if no current is measured when maximum field drive has been reached. This process will be repeated every 10 seconds.

11.1.5 Startup delay

In this state the AFC 300 will wait for the time set in its settings (9.4.4) before going to the “Charging” state.

11.1.6 Charging

When in the “Charging” state the AFC will try to control the current from the alternator by adjusting the field. The target current and voltage are determined by the BMS/Smartlink MX, its settings or the alternator temperature. If during this process the AFC 300 no longer detects any charging and the field drive already reached its maximum it will go back to the “Standby” state.

11.1.7 Failsafe

Some errors can cause the AFC 300 to enter “Failsafe”. Field is always disabled in the failsafe mode. The only way to leave this mode is by restarting the AFC 300 by repowering the device or restarting the device in the MG Connect App.

Errors causing device to enter failsafe:

- Overvoltage (load dump).

12 DIAGNOSTICS AND TROUBLESHOOTING

Diagnostic and troubleshooting can be achieved in several ways.

These tools can display the current status of the AFC 300

- MG Connect App ([documentation](#) for using the MG connect App) ([Apple](#) or [Android](#)).
- Status indicator (see chapter 7.5)

12.1 Troubleshooting procedure

Please use the following steps to increase your knowledge of how the AFC 300 should be connected and how it operates.

1. Consult the manual.
Manual can be found on the [MG Download Centre](#).
2. Watch the installation videos.
Videos can be found on [MG's You Tube channel](#).
3. Check your software version.
Check and update the products software version to latest using the MG Connect App ([Apple](#) or [Android](#)).

If you need further support;

- Contact [MG Service Point](#).
- Send [support request](#) with MG Connect App
- Contact MG technical support.
Send an email with your technical questions to support@mgenersystems.eu.

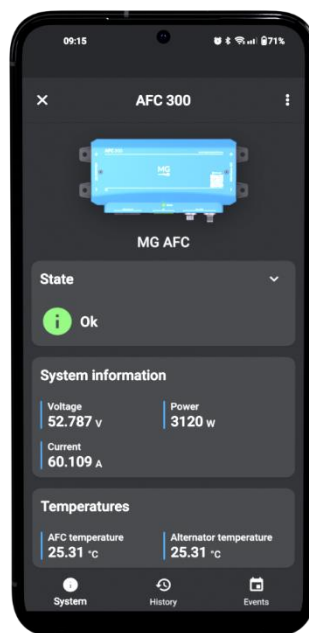

Figure 29 - Example MG Connect App on a phone

13 SERVICE

13.1 Maintenance

For maintenance it will be sufficient to inspect the following points once a year:

- Check the electrical connections on torque.
- Check if all communication connections are mated.
- Check for traces of water, oil, moisture, any other fluids or dust.
- Check for signs of corrosion.
- Clean the device.
- Check status with the [MG Connect App](#).



ELECTRICAL HAZARD:

Do not pour or spray water directly onto the device. When cleaning the device be aware that the connected battery string is a permanent energy source. Even when the device is turned off, the battery power connections might carry dangerous voltage levels.

13.1.1 Connections

It will suffice to check all connections once a year. Check if all connectors are mated correctly according the instructions given in sections of this manual.

13.1.2 Cleaning

Cleaning of the device is best done using a dry or slightly damp cloth. Limit the use of cleaning agents. If a cleaning agent is to be used, use an electrically non-conductive cleaning agent is advised.

It is important to keep the battery spaces clean and tidy in order to minimise the need for cleaning. Prevent the use of moisture, vaporizing agents, oil, grease, etc. in the vicinity of the device.

14 TECHNICAL SPECIFICATIONS

The technical specifications of this product can be downloaded from the MG Download Centre

<https://downloads.mgennergysystems.eu/afc/documents/technical-specification-en>

15 DIMENSIONS

The dimensions of this product can be downloaded from the MG Download Centre.

<https://downloads.mgennergysystems.eu/afc/drawings>

16 CONTACT DETAILS

For specific questions please feel free to contact us.



MG Energy Systems B.V.
Foeke Sjoerdswei 3
NL-8914 BH Leeuwarden
The Netherlands

16.1 Sales

For sales related questions, please contact a local dealer:

MG Dealer locations

<https://points.mgenergysystems.eu/>

For specific sales questions, please contact our sales team:

MG Sales team

sales@mgenergysystems.eu

16.2 Technical support

For technical support, please follow the steps below:

- Consult the manual.
Manual can be found on the [MG Download Centre](#).
- Watch the installation videos.
Videos can be found on [MG's You Tube channel](#).
- Check your software version.
Check and update the products software version to latest using the MG Connect App ([Apple](#) or [Android](#)).
- Contact [MG Service Point](#).
- Contact MG technical support.
Send an email with your technical questions to support@mgenergysystems.eu.